

CIDR環境でのDNS逆引き

Nissho Techno System Corporation
徳植 寛
toku@nissho-ele.co.jp

正引きの構造

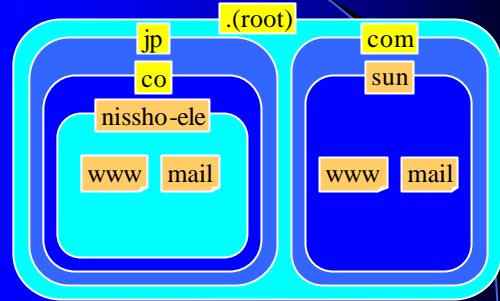

逆引きの構造

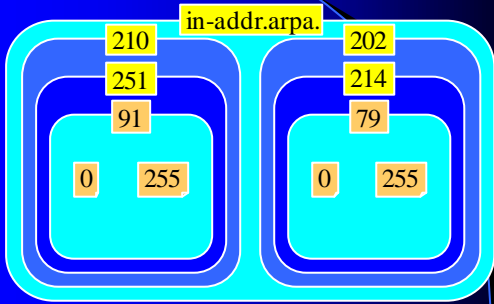

様々な逆引き

```
C
#include <stdio.h>
#include <netdb.h>

int main()
{
    struct in_addr *iaddr;
    struct hostent *hptr;
    char *str = "202.214.79.39";

    inet_aton(str, iaddr);
    hptr = gethostbyaddr(iaddr, sizeof(struct in_addr), AF_INET);
    printf("%s\n", hptr->h_name);
}
ns1.ij.ad.jp internet address = 202.232.2.35
```

CIDR技術の登場

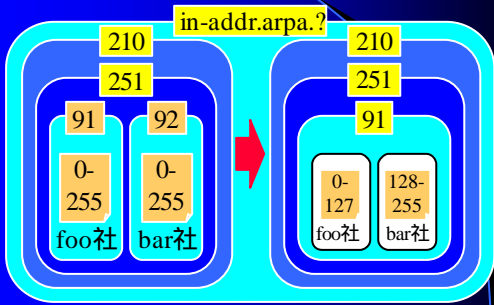

CIDR分割された逆引きの構造

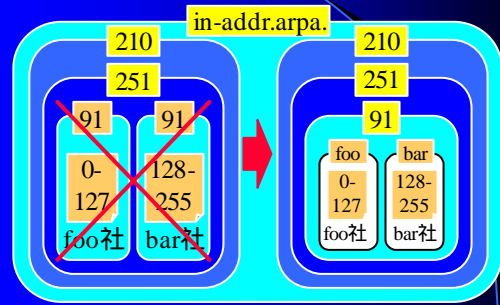

CIDR分割された逆引きの構造

